

CLARKE®

CONTRACTOR®



ROTARY HAMMER DRILL

MODEL NO: CON1500RDV

PART NO: 6479605

OPERATION & MAINTENANCE INSTRUCTIONS

UK
CA | CE



ORIGINAL INSTRUCTIONS

DL0123 - ISS 5

INTRODUCTION

Thank you for purchasing this CLARKE Hammer Drill. The CRD1500RDV is designed for general drilling/masonry drilling/chiselling/drill & hammer use in trade and light industrial applications.

Before attempting to use this product, please read this manual thoroughly and follow the instructions carefully. In doing so you will ensure the safety of yourself and that of others around you, and you can look forward to your purchase giving you long and satisfactory service.

GUARANTEE

This product is guaranteed against faulty manufacture for a period of 12 months from the date of purchase. Please keep your receipt which will be required as proof of purchase.

This guarantee is invalid if the product is found to have been abused or tampered with in any way, or not used for the purpose for which it was intended.

Faulty goods should be returned to their place of purchase, no product can be returned to us without prior permission. This guarantee does not effect your statutory rights.

INVENTORY

1	Blow-moulded Case	9	150 mm x 12 mm TCT Drill Bit
2	1500 Watt Rotary Hammer	10	Dust Shield Cup
3	Side Handle Assembly (fitted)	11	13 mm Keyed Chuck
4	Depth Stop Rod	12	SDS+ Chuck Adaptor (fitted to 13 mm chuck and including L.H.T. retaining screw)
5	250 mm Bull Point Chisel	13	Chuck Key
6	250 mm x 20 mm Flat Chisel	14	Pin Wrench
7	150 mm x 8 mm TCT Drill Bit	15	Accessory Storage Box
8	150 mm x 10 mm TCT Drill Bit	16	Pot of Grease (for SDS+ Chuck & Bit Shanks)

SAFETY PRECAUTIONS



WARNING: READ ALL INSTRUCTIONS. FAILURE TO FOLLOW ALL INSTRUCTIONS LISTED BELOW MAY RESULT IN ELECTRIC SHOCK, FIRE AND/OR SERIOUS INJURY. THE TERM "POWER TOOL" IN ALL WARNINGS LISTED BELOW REFERS TO YOUR HAMMER DRILL.

WORK AREA

1. **Keep work area clean and well lit.** *Cluttered and dark areas invite accidents.*
2. **Do not operate power tools in explosive atmospheres, such as in the presence of flammable liquids, gases or dust.** *Power tools create sparks which may ignite the dust or fumes.*
3. **Keep children and bystanders away while operating a power tool.** *Distractions can cause you to lose control.*

ELECTRICAL SAFETY

1. **Avoid body contact with earthed or grounded surfaces such as pipes, radiators, ranges or refrigerators.** *There is an increased risk of electric shock if your body is earthed or grounded.*
2. **Do not expose power tools to rain or wet conditions.** *Water entering a power tool will increase the risk of electric shock.*
3. **When operating a power tool outdoors, use an extension cord suitable for outdoor use.** *Use of a cord suitable for outdoor use reduces the risk of electric shock.*

PERSONAL SAFETY

1. **Stay alert, watch what you are doing and use common sense when operating a power tool. Do not use a power tool while you are tired or under the influence of drugs, alcohol or medication.** *A moment of inattention while operating power tools may result in personal injury.*
2. **Use safety equipment. Always wear eye protection.** *Safety equipment such as dust mask, non-skid safety shoes, or hearing protection used for appropriate conditions will reduce personal injuries.*
3. **Avoid accidental starting. Ensure the switch is in the off position before connecting to the power supply.**
4. **Do not overreach. Keep proper footing and balance at all times.** *This enables better control of the power tool in unexpected situations.*

5. **Dress properly. Do not wear loose clothing or jewellery. Keep your hair, clothing and gloves away from moving parts.** *Loose clothes, jewellery or long hair can be caught in moving parts.*







POWER TOOL USE AND CARE

1. **Do not force the power tool. Use the correct power tool for your application.** *The correct power tool will do the job better and safer at the rate which it was designed.*
2. **Do not use the power tool if the switch does not turn it on and off.** *Any power tool that cannot be controlled with the switch is dangerous and must be repaired.*
3. **Disconnect the power before making any adjustments, changing accessories, or storing power tools.** *Such preventive safety measures reduce the risk of starting the power tool accidentally.*
4. **Store idle tools out of the reach of children and do not allow persons unfamiliar with the power tool or these instructions to operate the power tool.** *Power tools are dangerous in the hands of untrained users.*
5. **Maintain power tools. Check for misalignment or binding of moving parts, breakage of parts and any other condition that may affect the power tools operation. If damaged, have the power tool repaired before use.** *Many accidents are caused by poorly maintained power tools.*
6. **Keep cutting tools sharp and clean.** *Properly maintained cutting tools with sharp cutting edges are less likely to bind and are easier to control.*
7. **Use the power tool and accessories in accordance with these instructions and in the manner intended for the particular type of power tool, taking into account the working conditions and the work to be performed.** *Use of the power tool for operations different from intended could result in a hazardous situation.*

SERVICE

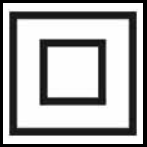
1. **Have your power tool serviced by a qualified repair person using only identical replacement parts.** *This will ensure that the safety of the power tool is maintained.*

SAFETY SYMBOLS

	Read instruction manual before use		Wear dust mask
	Class 2 Double Insulated		Wear ear defenders
	Weee Directive		Wear safety glasses

ENVIRONMENTAL RECYCLING POLICY



By purchasing this product, the customer is taking on the obligation to deal with its safe disposal in accordance with the Waste Electrical and Electronic Equipment (WEEE).

This product must not be disposed of with general household waste but be disposed of according to the laws governing Waste Electrical and Electronic Equipment (WEEE) at a recognised disposal facility.

This product contains valuable raw materials. Metal products should be taken to your local civic amenity site for recycling.

ELECTRICAL CONNECTIONS



WARNING: READ THESE ELECTRICAL SAFETY INSTRUCTIONS THOROUGHLY BEFORE CONNECTING THE PRODUCT TO THE MAINS SUPPLY.

Before switching the product on, make sure that the voltage of your electricity supply is the same as that indicated on the rating plate. Connecting it to any other power source may cause damage.

If it is necessary to change the fuse in the plug, the fuse cover must be refitted. If the fuse cover becomes lost or damaged, the plug must not be used until a suitable replacement is obtained.

If the plug has to be changed due to damage, a replacement should be fitted, following the wiring instructions shown below. The old plug must be disposed of as insertion into a mains socket could cause an electrical hazard.



**WARNING: THE WIRES IN THE POWER CABLE OF THIS PRODUCT ARE COLOURED IN ACCORDANCE WITH THE FOLLOWING CODE:
BLUE = NEUTRAL BROWN = LIVE**

If the colours of the wires in the power cable of this product do not correspond with the markings on the terminals of your plug, proceed as follows.

- The **Blue** wire must be connected to the terminal which is marked **N** or coloured **Black**.
- The **Brown** wire must be connected to the terminal which is marked **L** or coloured **Red**.

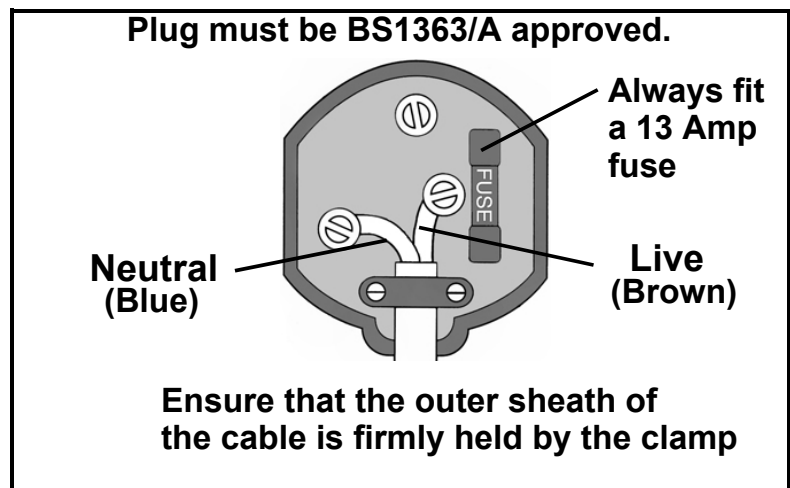

We strongly recommend that this machine is connected to the mains supply via a Residual Current Device (RCD)

If in any doubt, consult a qualified electrician. DO NOT attempt any repairs yourself.



This symbol indicates that this is a Class II product, and does not require an earth connection.

OVERVIEW

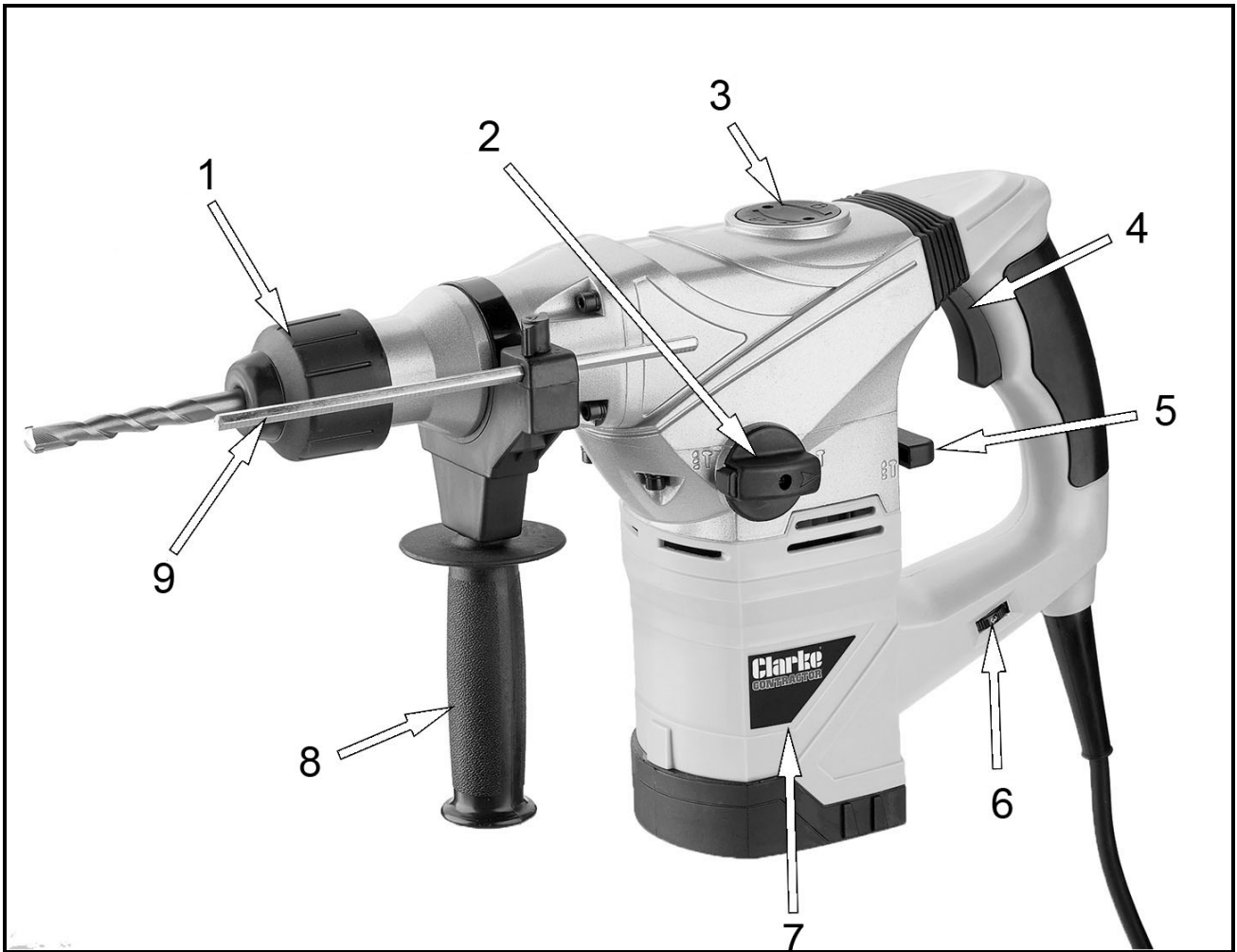

NO	DESCRIPTION	NO	DESCRIPTION
1	SDS Chuck	6	Speed Control
2	Rotation Stop Switch	7	Motor
3	Grease Port Cover	8	Front Handle
4	Trigger	9	Depth Stop
5	Hammer Action Selector		

BEFORE USE

POSITIONING THE FRONT HANDLE

The front handle can be positioned left, right or centre as required.

1. Loosen the handle by twisting it clockwise (when viewed from above).
2. Rotate the handle to the required position.
3. Secure the handle by twisting it anticlockwise (when viewed from above).

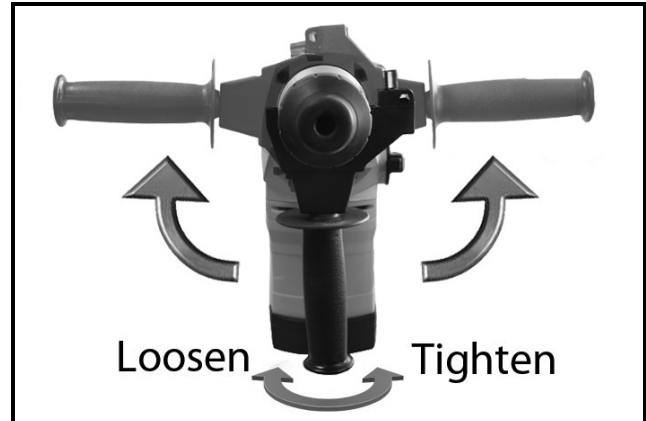

FITTING THE DEPTH STOP

The depth stop is fitted within the front handle and can only be used if this handle is fitted.

1. To install the depth stop, undo the thumbscrew until the depth stop can be passed through the opening.
2. To set the depth stop, release the thumbscrew and slide the rod in and out to the required position.

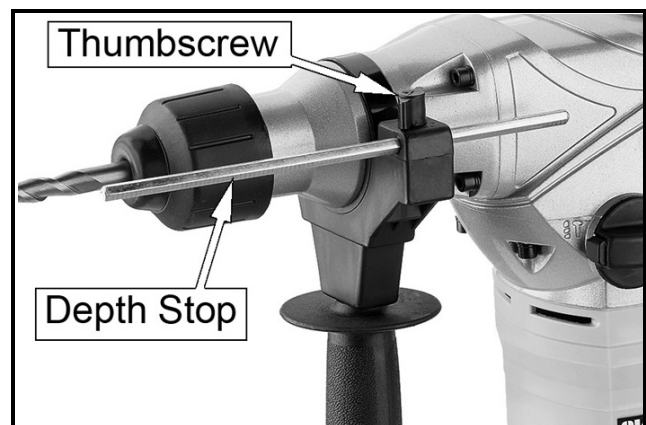

INSERTING A DRILL BIT / CHISEL

The chuck clamps SDS drill bits and chisels without the need for a chuck key.

1. Pull back the collar and insert the bit.
 - Turn the bit in the chuck until it latches.
2. Release the collar to lock in place.
3. Check by pulling the bit to see if it is locked in place.

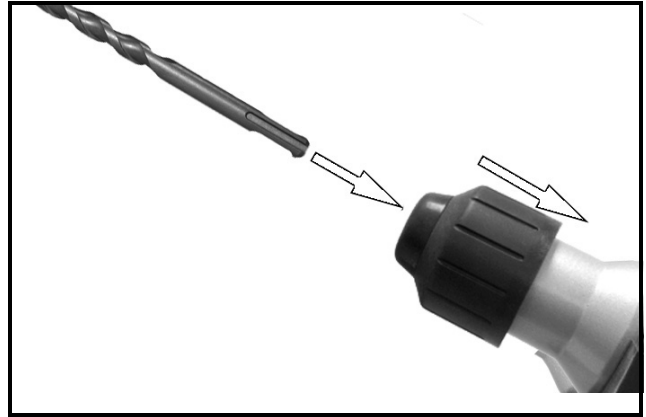

IMPORTANT: Always clean the shaft of the drill bit before inserting into the chuck.

IMPORTANT: Do not allow dust or debris inside the chuck as this will cause problems in the future.

REMOVING A BIT

1. Slide the collar to the rear and pull the bit out the chuck.



CAUTION: WHEN REMOVING A BIT FROM THE DRILL, REMEMBER THAT IT MAY BE EXTREMELY HOT. EITHER ALLOW IT TO COOL DOWN FIRST OR USE INDUSTRIAL GLOVES TO REMOVE THE BIT.

SELECTING THE OPERATING MODE



CAUTION: THESE OPERATIONS SHOULD ONLY BE PERFORMED WHEN THE DRILL IS AT A COMPLETE STOP.

Mode	Hammer Action selector	Rotation selector
Drill Only	Drill Only	ON
Hammer Drill	Hammer Assisted Drilling	ON
Hammer only (no rotation)	Hammer Assisted Chiselling	OFF

HAMMER ACTION SELECTOR

1. With the drill not operating, set the hammer action selector to the required setting.
 - Left - Hammer Assisted Drilling
 - Right - Drill Only

IMPORTANT: When using the “hammer action” you only need to apply light pressure. Too much pressure will place unnecessary load on the motor. Check the drill bits regularly, re-sharpen or replace if required.



ROTATION ON/OFF SELECTOR

Some jobs require the chuck to remain stationary yet still have the hammer effect, such as chiselling concrete, plaster etc.

- Set the rotation selector to the right for “no rotation”.
- Set the rotation selector to the left for “normal rotation”.

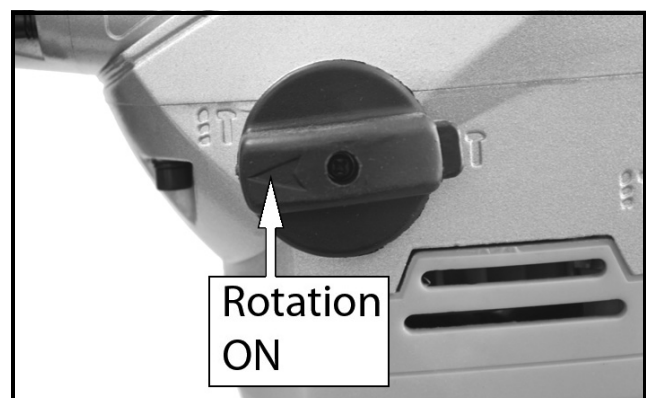
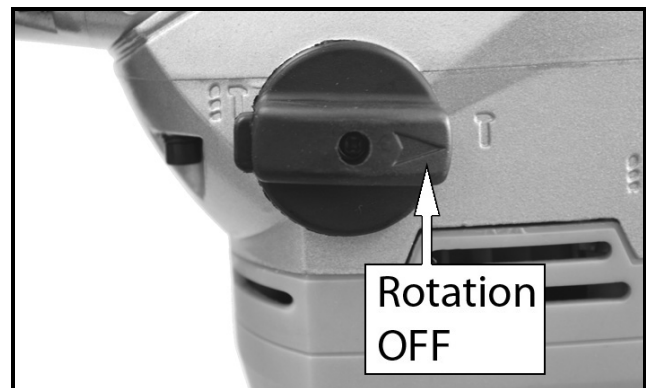

SPEED SELECTOR

The speed may be pre-selected by turning the variable speed control from 1 to 6.

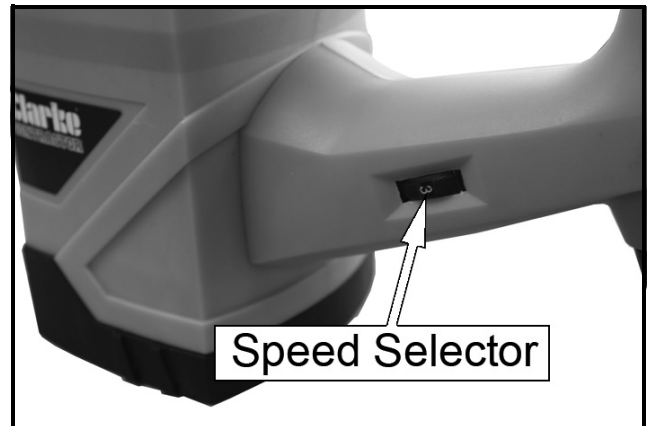

FITTING THE STANDARD CHUCK

1. Pull back locking sleeve and hold it back.
2. Insert the standard chuck.
3. Release the chuck collar.

NOTE: Make sure the chuck is secure before use.

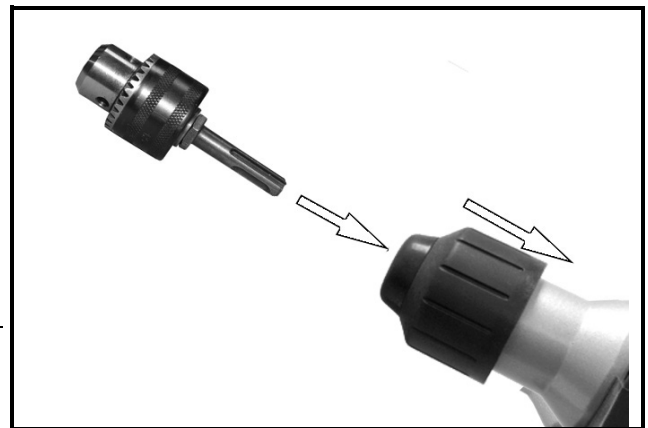

CAUTION: DO NOT USE THE STANDARD CHUCK IN HAMMER MODE

INSERTING A STANDARD DRILL BIT INTO NON-SDS CHUCK

1. Use the chuck key to open the chuck by rotating the chuck key anticlockwise until the jaws are open sufficiently to take the drill bit.
2. Place the drill bit in the jaws of the chuck as far as it will go.
3. Use the chuck key to tighten the chuck and secure the drill.

USING THE DRILL

BEFORE STARTING WORK

1. Before drilling into walls and floors etc., check first that there are no hidden electrical cables, gas or water pipes etc.
2. Check the mains voltage before plugging in and switching on.
3. Ensure the work area is as hazard free as possible.

STARTING WORK

1. Select and install the bit to be used. See page 9.
2. If required, adjust the front handle for the most comfortable position. See page 8.
 - Always hold the drill securely and use the auxiliary handle as shown.
3. Set the required operating mode. See page 10.
4. Set the required speed. See page 11.
5. When drilling vertically overhead, fit the rubber dust collector shown onto the drill bit.



6. Position the tool against the surface to be drilled and pull the trigger switch.
 - If using the hammer action, do not start the drill until the tool is in contact with the work surface.



STOPPING WORK

1. Release the trigger and wait until the bit has stopped before placing the drill on any surface

DRILLING TIPS

- Always use sharp, good quality drill bits. The performance of your drill is dependant on the quality of the bits used.
- After drilling material to the full depth, do not simply pull out the drill but maintain chuck rotation to ease withdrawal.
- Reduce the pressure on the drill bit when it is about to break through. This will prevent the drill from jamming.
- If drilling a large hole, first drill a pilot hole using a smaller drill bit.
- Always apply pressure to your drill bit in a straight line and, where possible, at right angles to the workpiece.
- When drilling in metal, the materials being drilled can become hot. To reduce overheating use a suitable cooling lubricant. No cooling lubricant is necessary when drilling cast iron or brass as they should be drilled dry.
- When drilling metal, the harder the metal the slower the drill speed. Similarly, the bigger the drill bit the slower the speed.
- To prevent the drill bit from slipping when starting to drill a hole in metal, use a centre punch to make an indentation at the start point.
- Always start drilling at a slow speed to prevent the drill from slipping out of the pop mark or indent, gradually increasing speed until the optimum cutting speed is achieved whilst maintaining a MODERATE pressure ONLY. NEVER force the drill bit into the work. This will overheat the tip and cause it to dull very quickly.
- When drilling in wood, clamp a piece of scrap wood to the underside of the material to avoid splintering.
- Large holes should be drilled with wood augers, flat wood bits or hole saws.

MAINTENANCE AND SERVICING



WARNING: MAKE SURE THAT THE DRILL IS SWITCHED OFF AND DISCONNECTED FROM THE MAINS SUPPLY BEFORE STARTING ANY CLEANING OR MAINTENANCE PROCEDURES.

BEFORE USE

1. Ensure all fixing screws remain tight to ensure the drill is in safe working condition.
2. Inspect the power cable to ensure it is free from cracks, bare wires etc.

CLEANING

1. Ensure all air ventilation slots are clear of blockages, (use compressed air to clean the machine if possible).
2. After use, clean all dust and swarf from the drill.
3. Clean the exterior of the drill with a soft cleaning cloth. Never use any chemicals or harsh abrasives to clean the tool.
 - Avoid using solvents when cleaning plastic parts; most plastics are susceptible to damage from various types of commercial solvents.

GEARBOX GREASE

After extensive use, grease may be added to the hammer drill mechanism via the grease port cover.

1. Remove the grease port cover using the wrench supplied.
2. Apply sufficient grease to cover all visible moving parts
 - DO NOT overfill the gearbox.
3. Replace the grease port cover and hex bolts before using the drill again.
 - All other bearings etc, in this tool are lubricated with sufficient high grade lubricant for the tools lifetime under normal operating conditions, therefore no further lubrication is necessary.
 - There are no other user serviceable parts in this machine. Refer to your CLARKE dealer if internal maintenance is required.

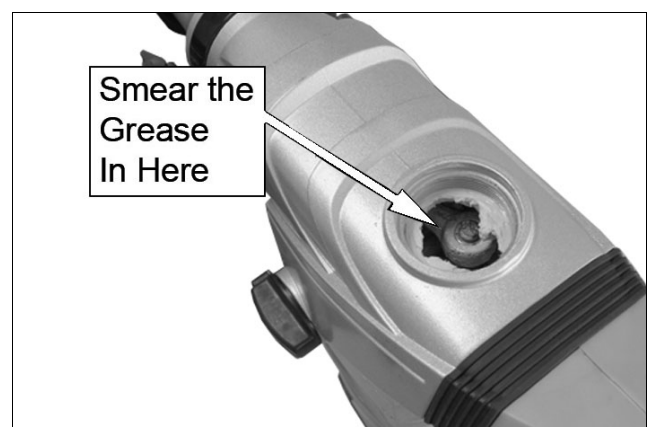

SPECIFICATIONS

Voltage / Frequency		230Vac~ 50Hz -1ph	
Rated Input Power		1500 Watts	
Electrical Class		II	
IP Rating		IP20	
Chuck capacity/type		SDS Plus 13mm keyed chuck adapter	
Rotational Speed		200 -750 rpm	
Impact Rating		650 - 3000 (blows/min)	
Maximum Drilling Capacity:		Wood	40 mm
		Steel	13 mm
		Concrete	36 mm
Sound Pressure Level	Rotary hammer	96.66 dB LpA	
	Chiselling hammer	95.86 dB LpA	
Sound Power Level	Rotary hammer	107.66 dB LWA	
	Chiselling hammer	106.66 dB LWA	
Vibration		Main Handle	Front Handle
	Rotary hammer	8.338 m/s ²	7.758 m/s ²
	Chiselling hammer	19.581 m/s ²	15.644 m/s ²
Weight (drill only)		5.95 kg	
Dimensions (LxHxW)		410 x 259 x 144 mm	
Duty Cycle classification		S1 Continuous	

PARTS DIAGRAM

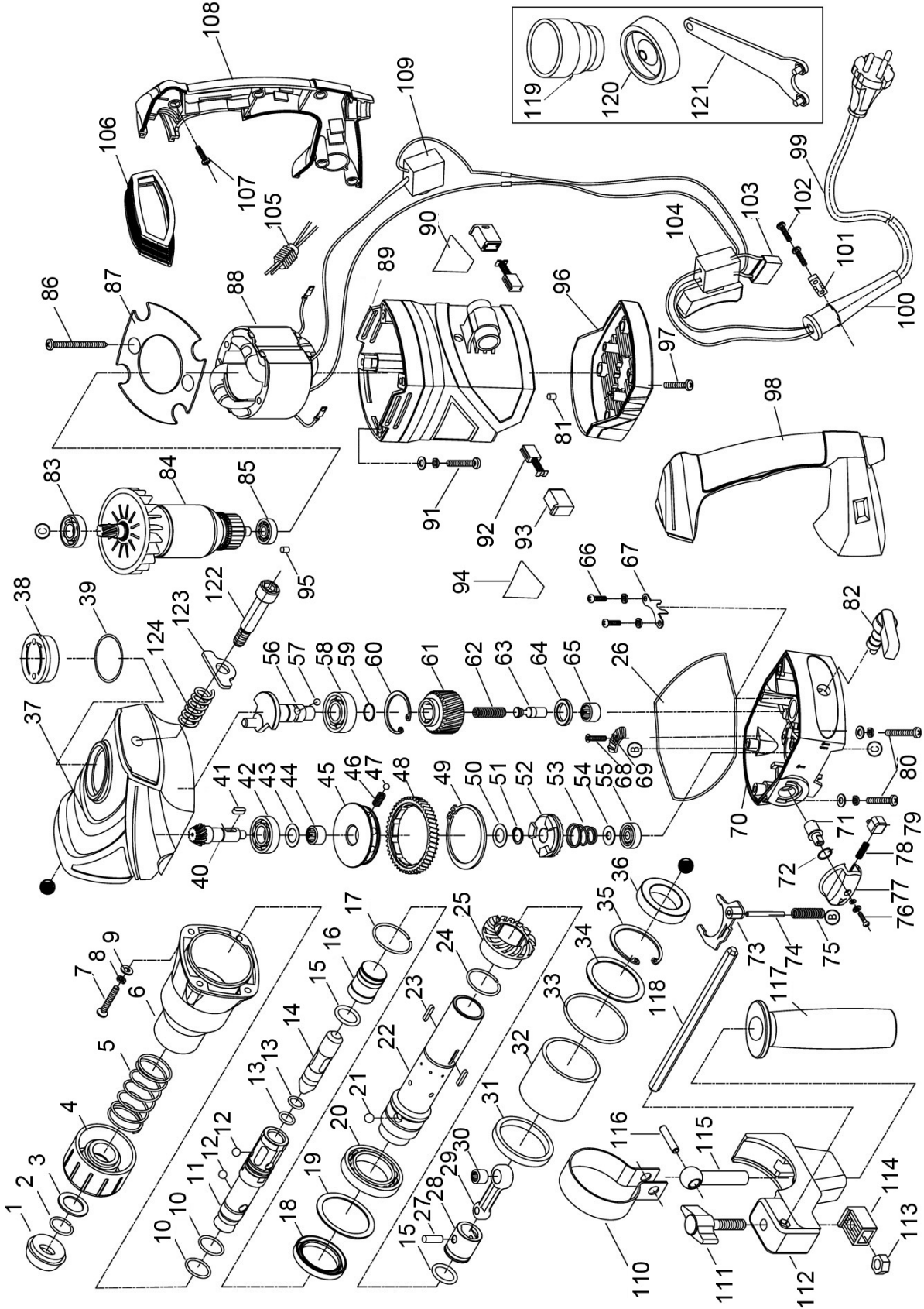

PARTS LIST

NO	DESCRIPTION	NO	DESCRIPTION
1	Front Cover	33	O Ring
2	Circlip	34	Locating Washer
3	Washer	35	Circlip
4	Chuck Sleeve	36	Oil Seal
5	Spring	37	Crank Shaft Case
6	Cylinder Case	38	Grease Port Cover
7	Bolt	39	O Ring
8	Spring Washer	40	Small Bevel Gear
9	Flat Washer	41	Pin
10	O Ring	42	Bearing
11	Guard Ring Sleeve	43	Washer
12	Steel Ball	44	Needle Bearing
13	O Ring	45	Core
14	Second Striker	46	Spring
15	O Ring	47	Steel Ball
16	Ram	48	Second Gear
17	Circlip	49	Circlip
18	Grease Seal	50	Washer
19	Washer	51	Circlip
20	Bearing	52	Clutch
21	Steel Ball	53	Disc Spring
22	Cylinder	54	Washer
23	Key	55	Bearing
24	Circlip	56	Crankshaft
25	Bevel Gear	57	Steel Ball
26	Seal Strip	58	Bearing
27	Piston Pin	59	Circlip
28	Piston	60	Circlip
29	Connecting Rod	61	First Gear
30	Needle Bearing	62	Spring

NO	DESCRIPTION
31	Rubber Ring
32	Sleeve Block
65	Needle Bearing
66	Screw
67	Lock Plate
68	Screw
69	Stop Plate
70	Gear Case
71	Eccentric Shaft
72	Circlip
73	Striking Fork
74	Pin
75	Spring
76	Screw
77	Knob
78	Knob Spring
79	Locating Piece
80	Screw
81	Screw
82	Switch Knob
83	Bearing
84	Rotor
85	Bearing
87	Air Deflector
88	Stator
89	Motor Housing
90	Label
91	Screw
92	Carbon Brush
93	Brush Holder
94	Label
95	Screw

NO	DESCRIPTION
63	Spindle
64	Wear Ring
96	Bottom Cover
97	Self-tapping Screw
98	Left Handle
99	Power Cable
100	Cable Sheath
101	Cable Clamp
102	Self-tapping Screw
103	Capacitor
104	Switch
105	Inductor
106	Anti-vibration Ring
107	Self-tapping Screw
108	Right Handle
109	Speed Control
110	Clamp Collar
111	Thumbscrew
112	Front Handle Clamp
113	Nut
114	Depth Stop Clamp
115	Bolt
116	Straight Pin
117	Front Handle
118	Depth Stop
119	Grease Pot
120	Dust Cap
121	Spanner
122	Anti-vibration Bolt
123	Anti-vibration Washer
124	Anti-vibration Spring

DECLARATION OF CONFORMITY



Hemmill Street, Epping, Essex CM16 4LG

DECLARATION OF CONFORMITY

This is an important document and should be retained.

We hereby declare that this product(s) complies with the following statutory requirement(s):

Electromagnetic Compatibility Regulations 2016
Supply of Machinery (Safety) Regulations 2008
The Restriction of the Use of Certain Hazardous Substances in Electrical and Electronic Equipment Regulations 2012

The following standards have been applied to the product(s):

EN 55014-2:1997+A2, EN 55014-1:2017+A11, EN IEC 55014-1:2021, EN IEC 55014-2:2021,
EN 61000-3-3:2013, EN 61000-3-3:2013+A2, EN 61000-3-2:2014, EN IEC 61000-3-2:2019+A1,
EN ISO 12100:2010, EN 62841-1:2015, EN IEC 62841-2-6:2020+A11, IEC 62321-3-1:2013,
IEC 62321-5:2013, IEC 62321-4:2013, EN 62321:2009, EN 62321:2009, EN 62321:2009

The technical documentation required to demonstrate that the product(s) meet(s) the requirement(s) of the aforementioned legislation has been compiled and is available for inspection by the relevant enforcement authorities.

The UKCA mark was first applied in: 2021

Product Description: Rotary Hammer Drill
Model number(s): CONT1500RDV
Serial / batch Number: N/A
Date of Issue: 04/01/2023

Signed:

J.A. Clarke
Director



Fitzwilliam Hall, Fitzwilliam Place, Dublin 2

DECLARATION OF CONFORMITY

This is an important document and should be retained.

We hereby declare that this product(s) complies with the following directive(s):

2014/30/EU Electromagnetic Compatibility Directive
2006/42/EC Machinery Directive
2011/65/EU RoHS (Restriction of Hazardous Substances) Directive

The following standards have been applied to the product(s):

EN 55014-2:1997+A2, EN 55014-1:2017+A11, EN IEC 55014-1:2021, EN IEC 55014-2:2021,
EN 61000-3-3:2013, EN 61000-3-3:2013+A2, EN 61000-3-2:2014, EN IEC 61000-3-2:2019+A1,
EN ISO 12100:2010, EN 62841-1:2015, IEC 62321-3-1:2013, IEC 62321-5:2013, IEC 62321-4:2013,
EN 62321:2009, EN 62321:2009, EN 62321:2009

The technical documentation required to demonstrate that the product(s) meet(s) the requirement(s) of the aforementioned directive(s) has been compiled and is available for inspection by the relevant enforcement authorities.

The CE mark was first applied in: 2011

Product Description: Rotary Hammer Drill
Model number(s): CONT1500RDV
Serial / batch Number: N/A
Date of Issue: 04/01/2023

Signed:

J.A. Clarke
Director

A SELECTION FROM THE VAST RANGE OF

Clarke®

QUALITY PRODUCTS



AIR COMPRESSORS
From DIY to industrial, Plus air tools, spray guns and accessories.

GENERATORS
Prime duty or emergency standby for business, home and leisure.

POWER WASHERS
Hot and cold, electric and engine driven - we have what you need

WELDERS
Mig, Arc, Tig and Spot. From DIY to auto/industrial.

METALWORKING
Drills, grinders and saws for DIY and professional use.

WOODWORKING
Saws, sanders, lathes, mortisers and dust extraction.

HYDRAULICS
Cranes, body repair kits, transmission jacks for all types of workshop use.

WATER PUMPS
Submersible, electric and engine driven for DIY, agriculture and industry.

POWERTOOLS
Angle grinders, cordless drill sets, saws and sanders.

STARTERS/CHARGERS
All sizes for car and commercial use.

PARTS & SERVICE: 0208 988 7400

Parts Enquiries
Parts@clarkeinternational.com

Servicing & Technical Enquiries
Service@clarkeinternational.com

SALES: UK 01992 565333 or Export 00 44 (0)1992 565335

Clarke INTERNATIONAL Hemnall Street, Epping, Essex CM16 4LG
www.clarkeinternational.com